



N F P A

Fluid Power

=VEHICLE

Challenge



NFPA
Education and
Technology
Foundation

Final Presentation & Design Review

TEAM: NIU@RVC

TEAM ADVISOR: Dr. Ghazi Malkawi

DATE: 4/24/2026



Team Introduction



Daniel Alcalá



Hayden Brown



Max Meyer



Gavin Gates



Liam O'Sullivan



Lars Jameson

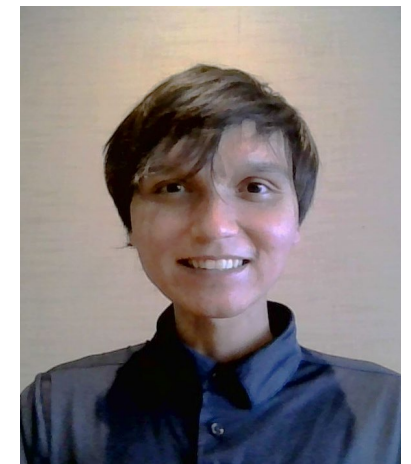

Tristan Hendler

Old vs New Vehicle Design



2025

Weak Points

- **Pedal-to-pump:** 1:1.78 ratio
- **Layout:** Bulky, sporadic component placement
- **Hydraulic Schematic:** Longer hosing, larger manifold
- **Weight:** 162 lbs.
- **Powertrain:** Standard chain & sprocket with derailleur system

Improvements

- **Pedal-to-pump:** 1:5 ratio
- **Layout:** Compact, more structurally stable
- **Hydraulic Schematic:** Shorter hosing, more compact manifold
- **Weight:** 148 lbs.
- **Powertrain:** Pneumatic gearbox & belt drive system



2026

Frame Modifications & FEA Analysis

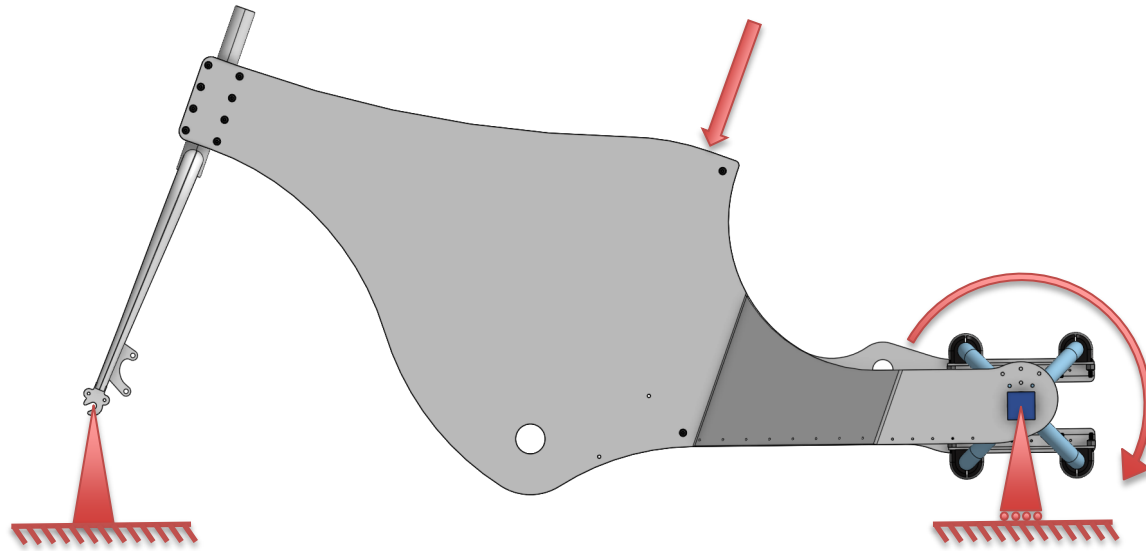

Simulation Software: Onshape Simulations
FEA Loads Applied: 400lbf applied to seat, 100lb-ft torque applied to rear axle

Materials Used: Laser CNC cut 1/8" Aluminum Plates (*Inner: 6061-T6, Outer: 5052-H32*), stacked to create 1/4" thick plates each side, connected by standoffs/machine screws

Most Effective Weight Reduction Pattern: Triangular shapes with radiused inner corners, alternating orientation

Results:

- **Maximum Deformation:** 0.015"
- **Maximum Equivalent Stress:** 3000 psi
- **Safety Factor:** 9.3

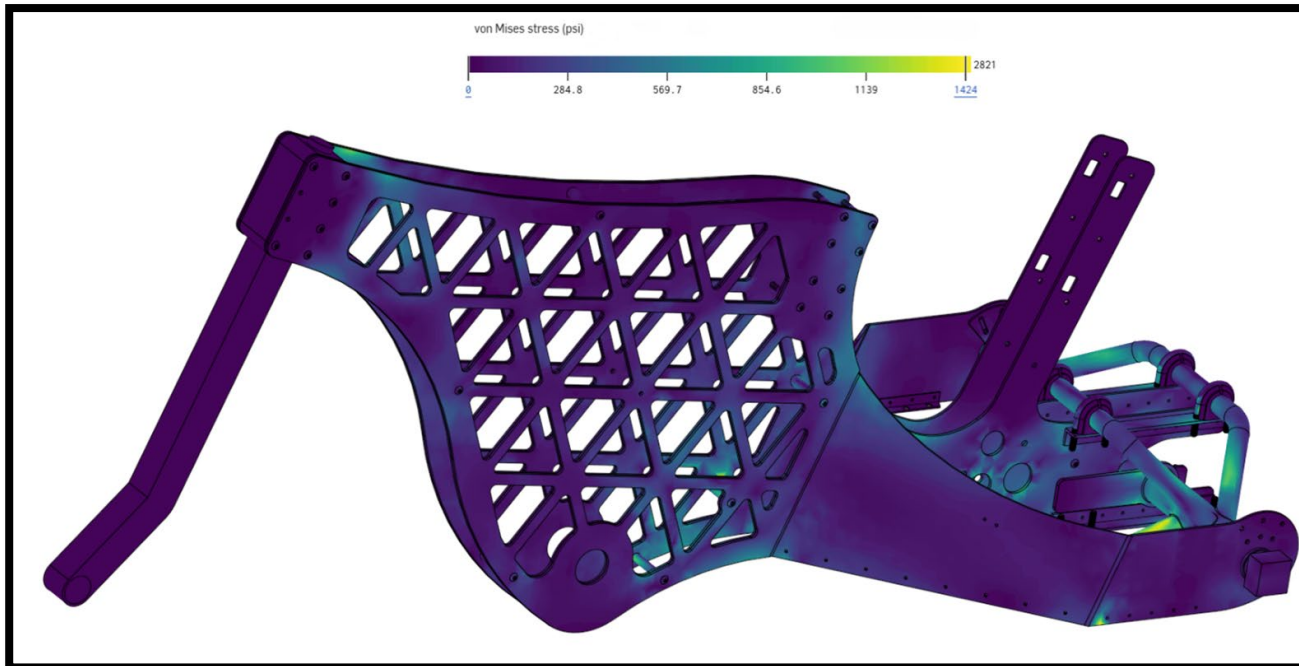

Pneumatic Gearbox Design



The addition of a pneumatically actuated gearbox was included in the 2026 design

- 4-speed gearbox
 - Gear 1 (*left*), Gear 2 (*middle-left*), Gear 3 (*middle-right*), Gear 4 (*right*)
 - Controlled using independent pneumatic system (*shown in top left image*), with the solenoids actuating at a regulated pressure of 40 psi

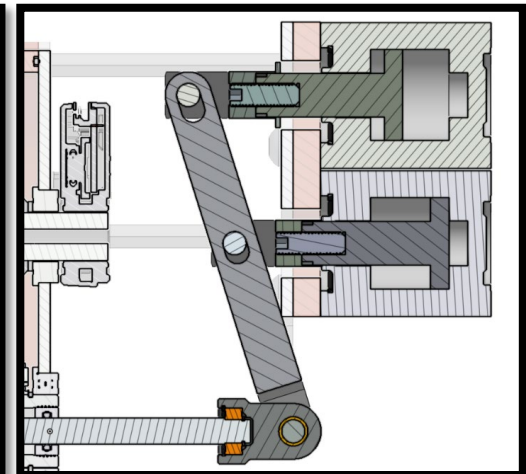
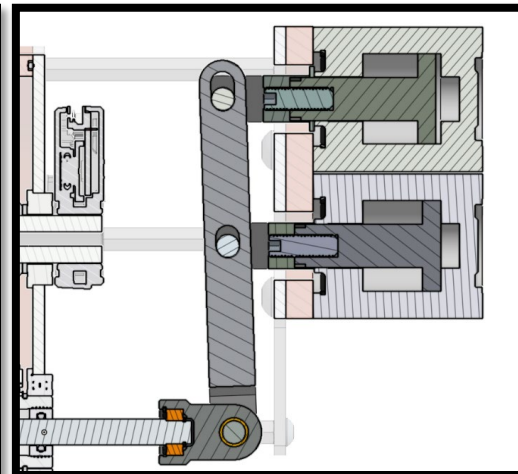
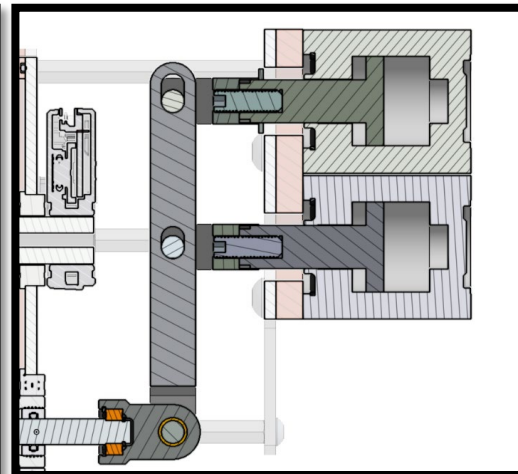
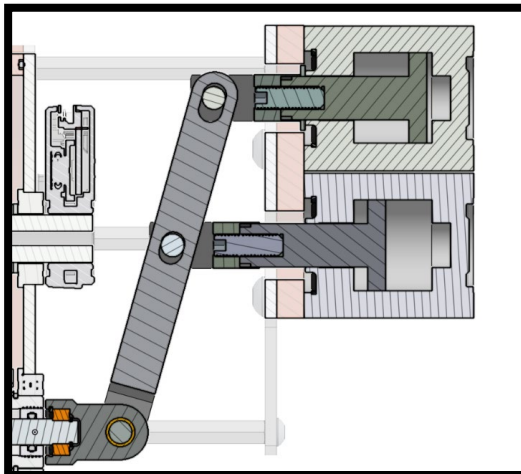
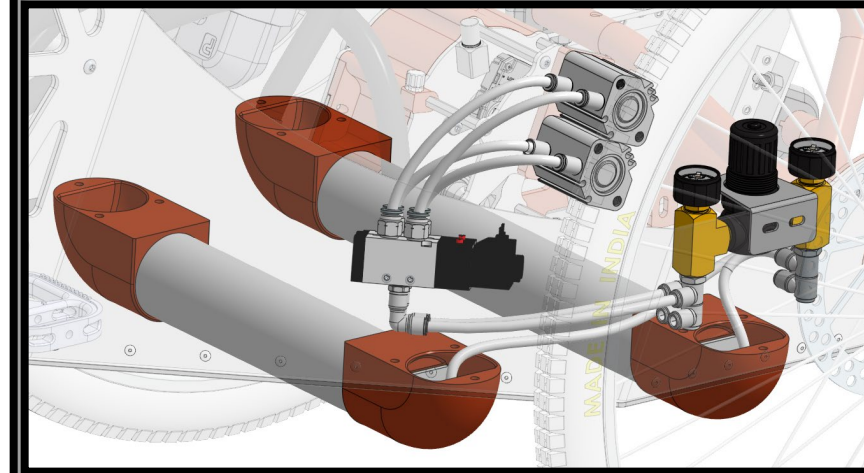
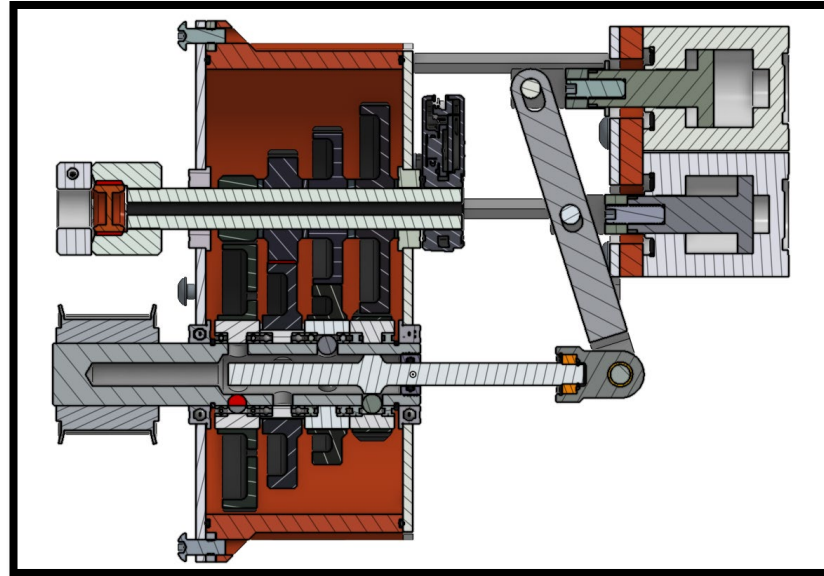

Improved Gear Ratios



Last Year: Pedal to Pump		
Pedal Sprocket	Pump Sprocket	Ratio
32	18	1:1.78

This Year: Pedal to Pump		
Pedal Pulley	Pump Sprocket	Ratio
90	18	1:5

This Year: Gearbox Ratios			
Selected Gear	Input Gear	Output Gear	Ratio
1	16	68	4.25:1
2	28	56	2:1
3	40	44	1.1:1
4	52	32	1:1.61

This Year: Gearbox to Axle		
Gearbox Pulley	Axle Pulley	Ratio
20	60	3:1

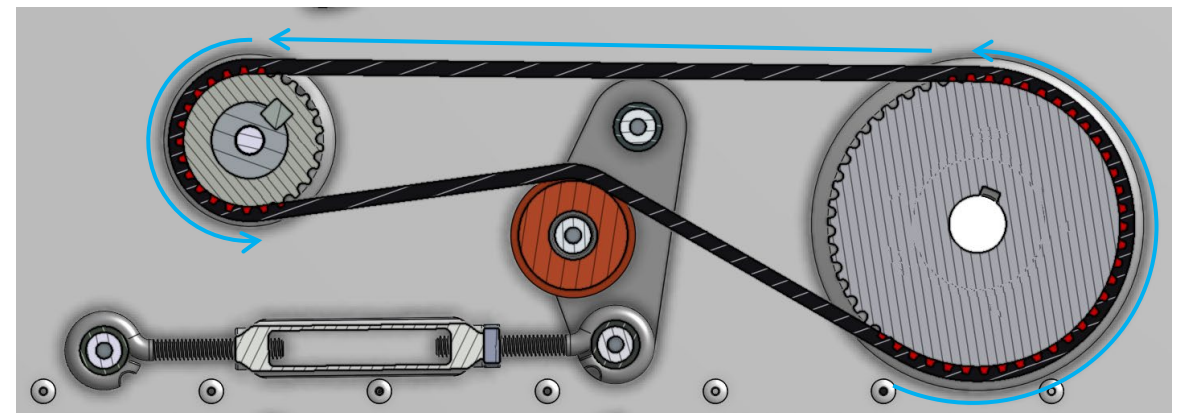
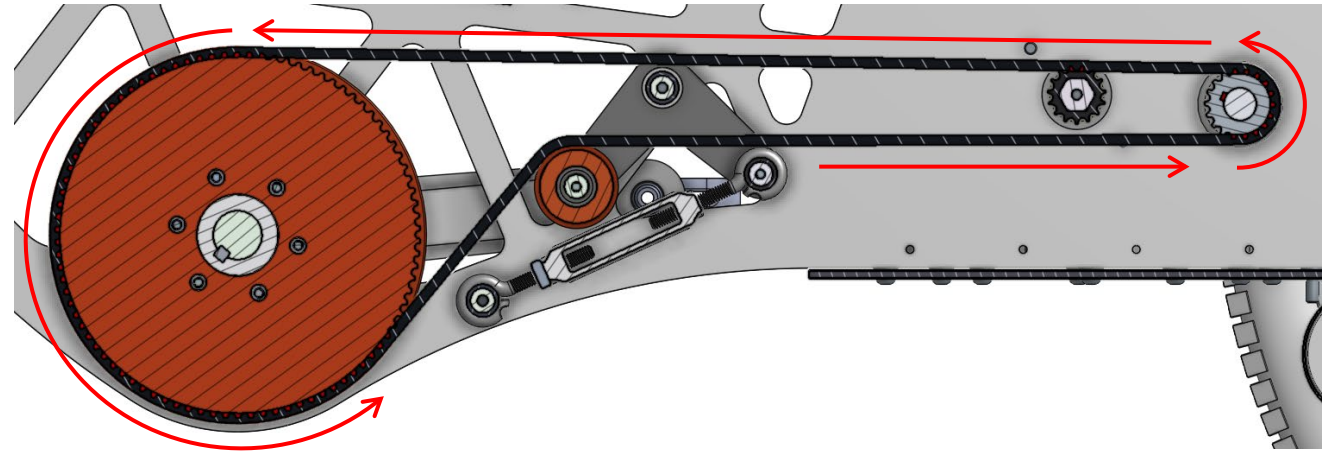

The updated power transmission system used in the 2026 vehicle utilizes a system of 3D printed/aluminum pulleys, connected with belts (compared to a typical bicycle chain/sprocket used in previous years). This allows for a smoother transmission of power and easier adjustability within the system in terms of gear ratios.

Custom Hydraulic Mounting Brackets



Pump & Motor Drives

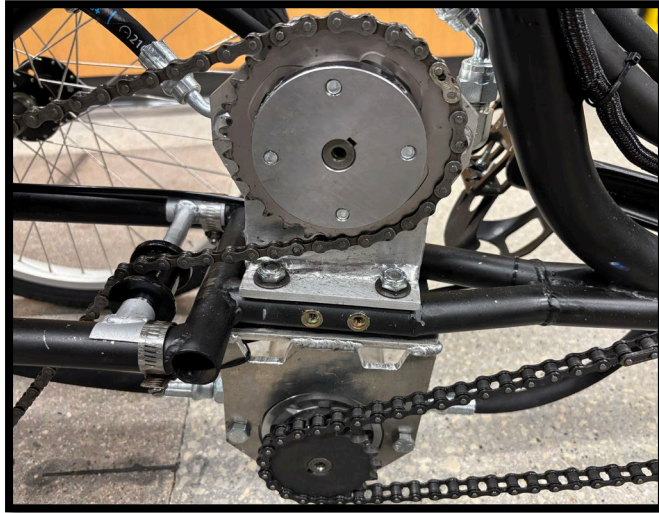

2025

Hydraulic Component Mounting

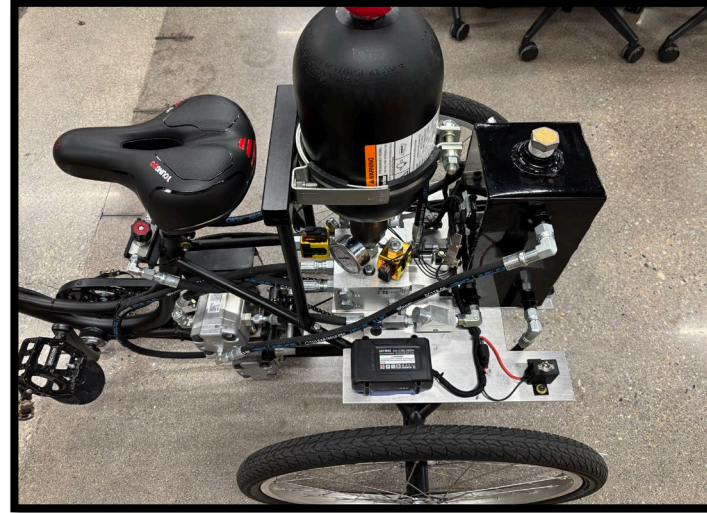

Pump & Motor Drives:

- Smooth belt drive
- Low speed efficient gearing
- High pump rpm (5:1)
- Minimal cavitation

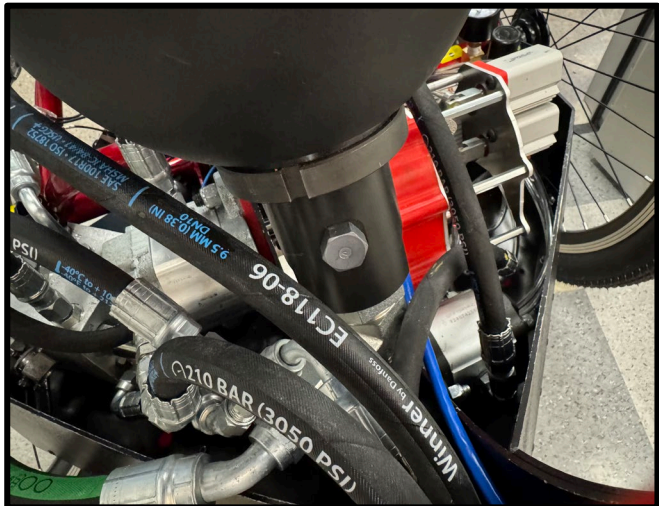

2026



Component Mounting:

- Low center of gravity
- Integrated reservoir
- Rigid mounting

Chain Clearance & Safety

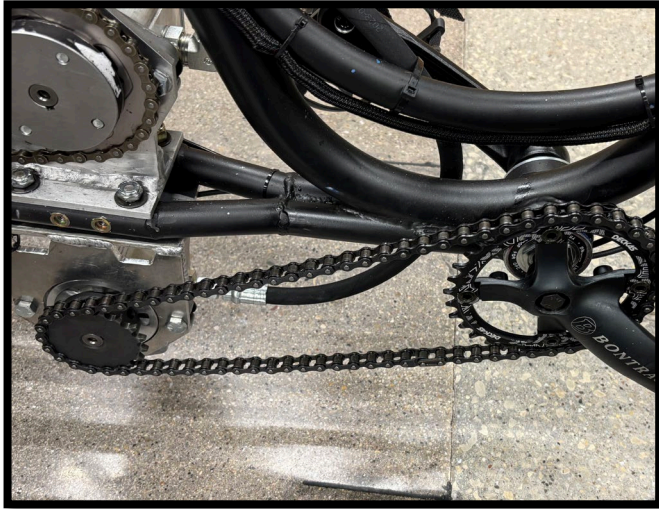

2025



Chain Interference:

- Chain are mostly exposed.
- Hydraulic lines near pedals



2026

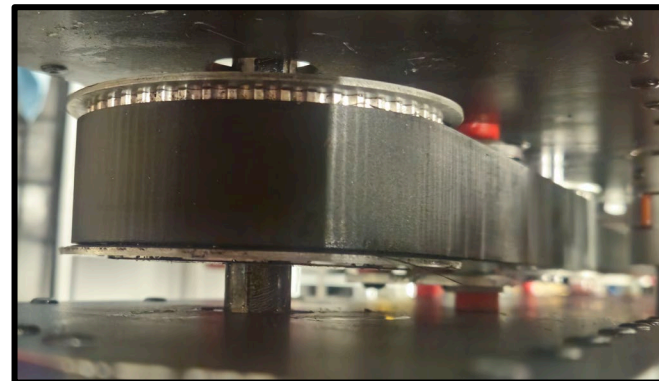

Belt Safety:

- Belt driven components
- Hidden between frame
- Lighter than chain
- 3D printed pulley

Old vs New Hydraulic Schematic

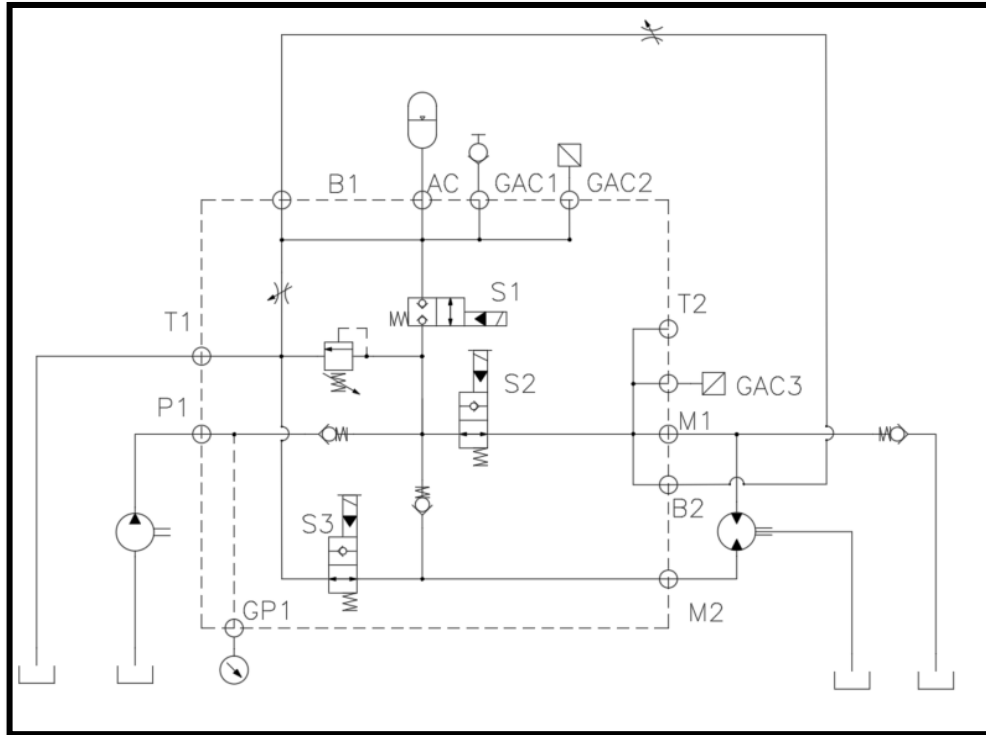

Old Schematic Weak Points

- Excessive hosing for pressure release mechanism
- Larger heavier manifold with 3 solenoids.

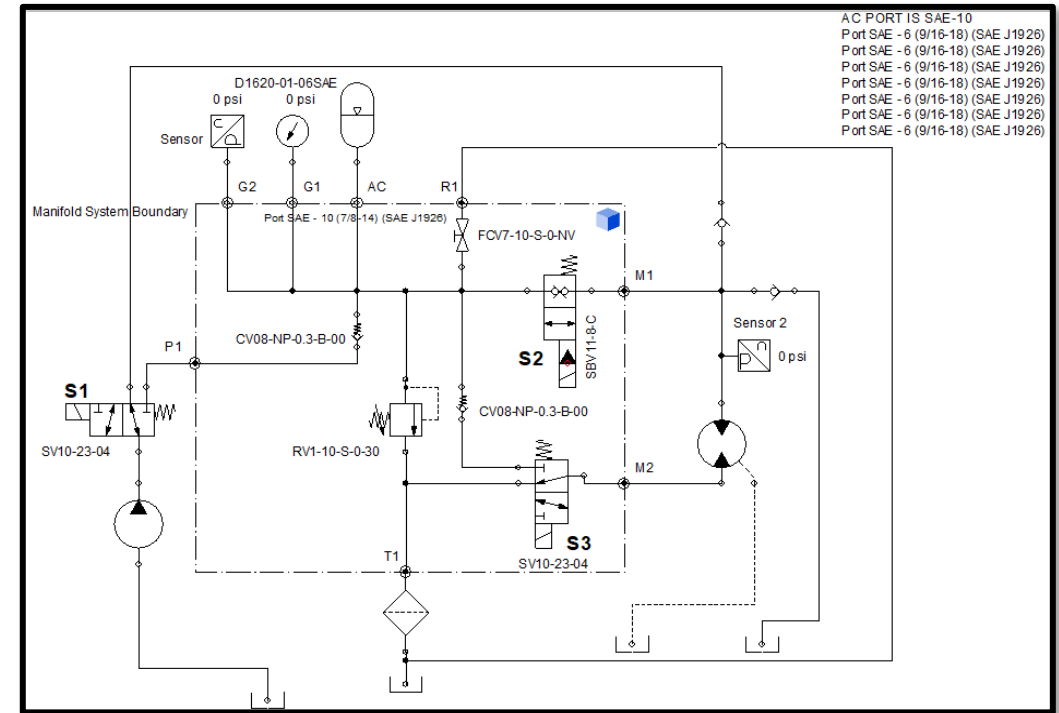

New Schematic Improvements

- Smaller manifold, added line body
- Needle valve for safety
- Efficient direct drive

Old Hydraulic System



Weak Points

- Larger pump and motor
- Lengthy hosing
- Obtrusive reservoir

New Hydraulic System

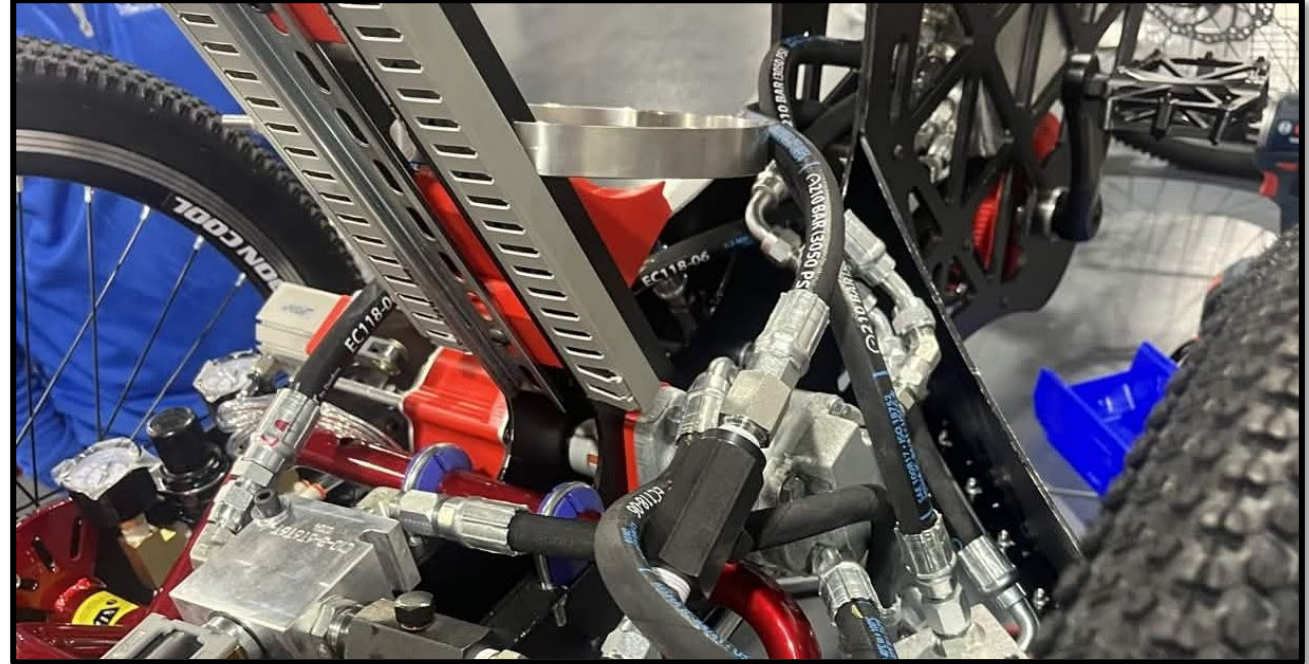

Improvements

- Compact hosing
- Smaller pump and motor
- Needle valve
- Integrated reservoir

Hydraulic Components



2025



Danfoss
Gear Pump
10.8cc/rev

Danfoss
Gear Motor
16.8cc/rev

Old Reservoir

- Adds weight to back
- Takes up space on back



2026



IFP
Gear Pump
4.1cc/rev

Concentric
Gear Motor
4.0cc/rev

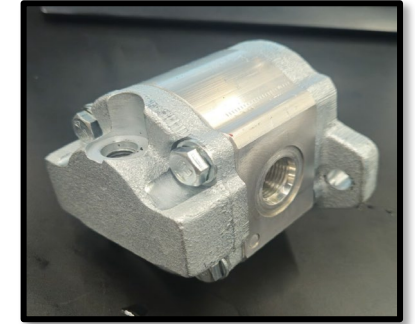

Parker
Bladder Accumulator
1 Gallon



New Reservoir

- Similar capacity but slimmer.
- Mounted between frame plates.
- Inlets and outlets are closer.

Old vs New Hydraulic Controls System



2025 Features

- Danfoss button operated display
- Pressure displays
- Speed display
- Mode selection



2026 Improvements

- Mounted buttons to select drive mode
- Increased riding safety and ergonomics
- Pressure monitored via dial pressure gauges
- Lower cost



Old vs New Gear Shift System



2025 Weak Points

- Standard handlebar gear shifter
- Hard to shift in motion
- Delay to shifting



2026 Improvements

- Handlebar mounted button connected to PLC
- Improved shifting ease and responsiveness



Gear Shift Program

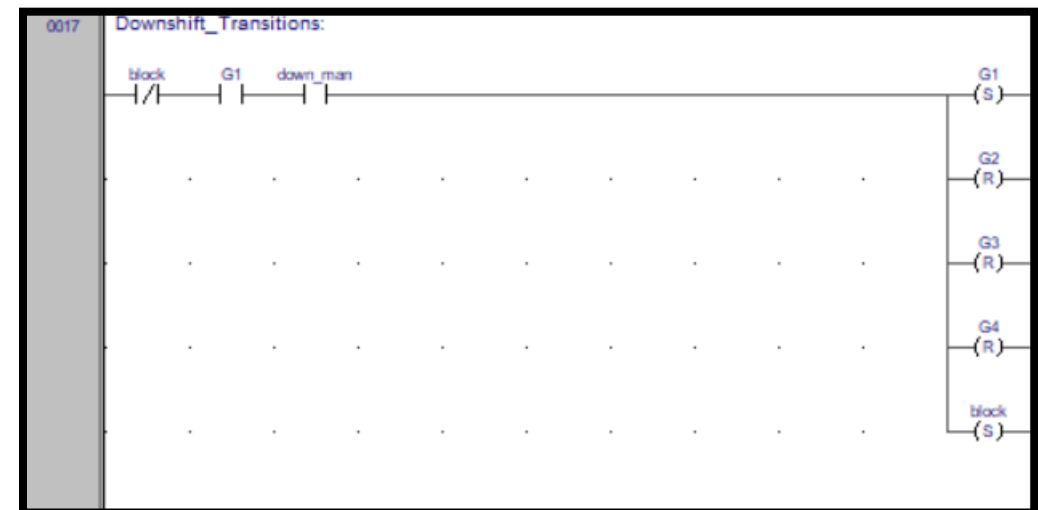
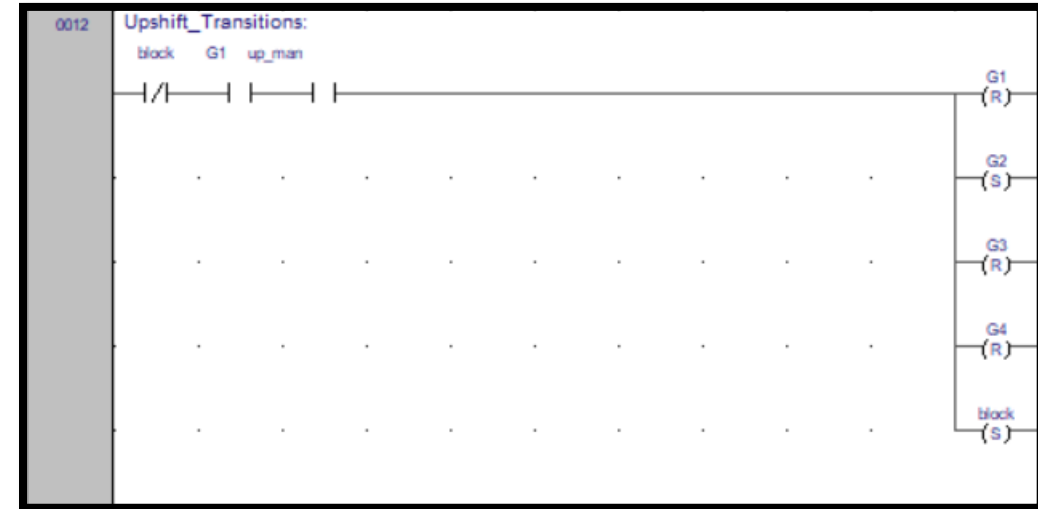
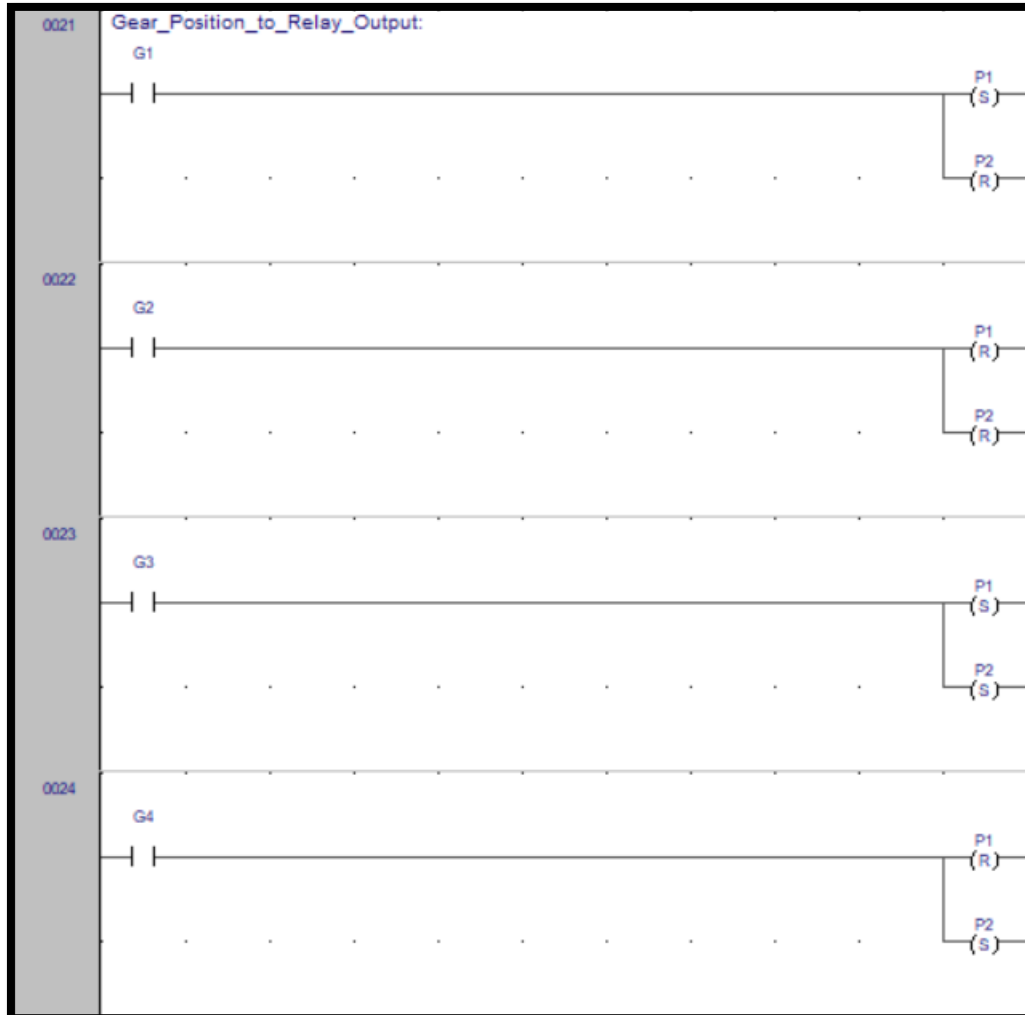

Controls Wiring

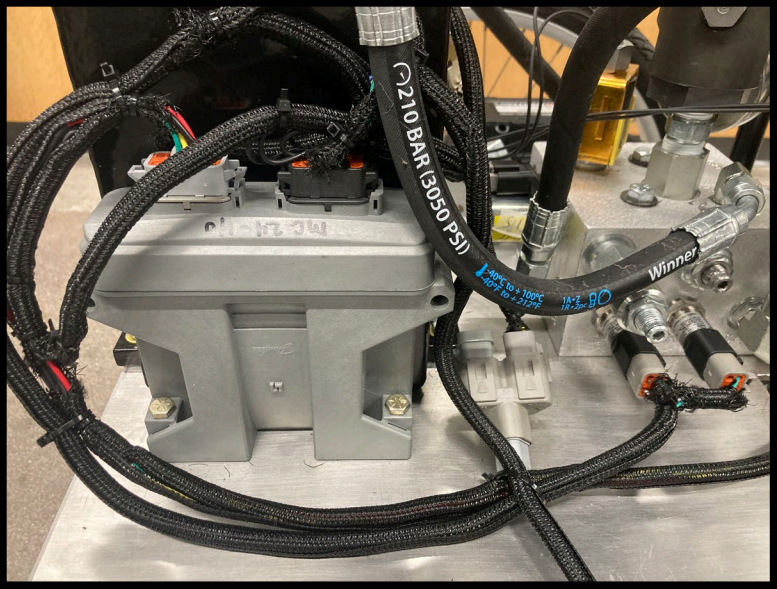
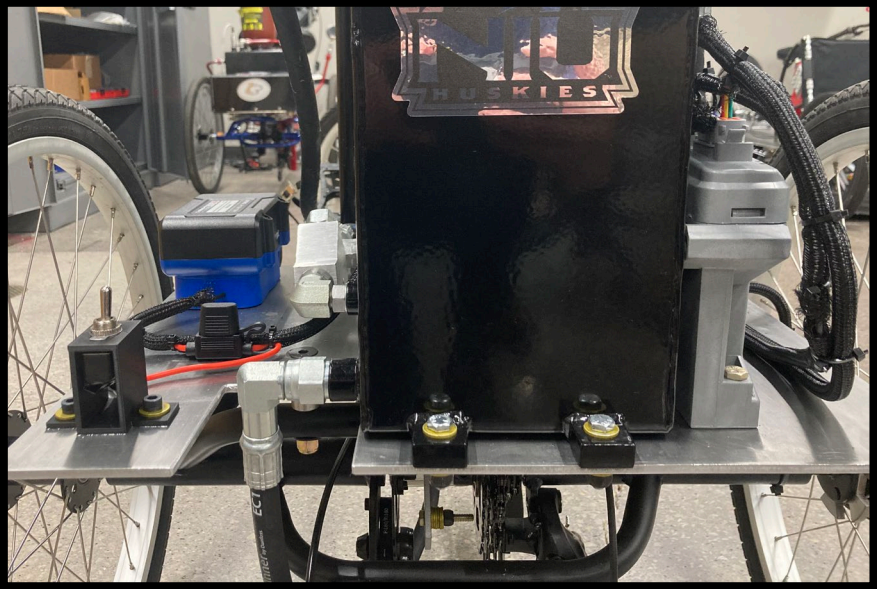

2025 Weak Point

- Wiring is loose with excess

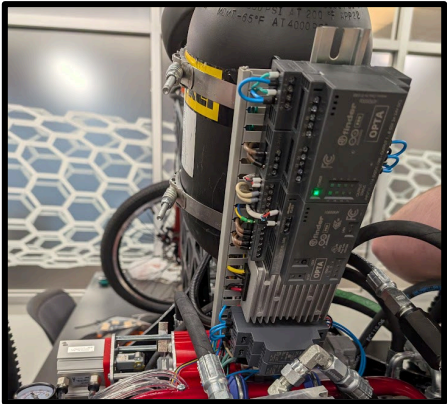

2026 Improvement

- Wiring is bound closer to the frame and components

Vehicle Testing



- Sprint
 - First test: 900 psi pre-charge at 2500 psi – used gears 1 thru 3 – top speed of 13.8 mph – time of 20.5 seconds
 - Best test: 900 psi pre-charge at 2900 psi – used gears 1 & 2 – top speed of 19.8 mph – time of 14.75 seconds
- Endurance
 - 2025 bike test: 5069 ft in 7:26 (average speed of 7.8 mph)
 - 2026 bike test: 4893 ft in 6:57 (average speed of 8.0 mph)

Vehicle Testing Cont.



- Regenerative Braking Test
 - Accumulator pre-charge of 900 psi
 - Drove to 7.2 mph in 1st gear, braked to 1500psi
 - Went 15.6 ft off regen charge
- Efficiency Test
 - Optimal efficiency 6%
 - Accumulator pre-charge of 900 psi
 - Hydraulic pressure of 2900 psi
 - Distance travelled of 797ft
 - **Up pre-charge for competition**

Lessons Learned



Frame:

- Having an up-to-date CAD model ensures that Finite Element Analysis models are as accurate as possible, essential for the weight reduction plan for using custom frame plates.
- Incorporating tolerances in designing the model are essential to account for real world design.
- Having multiple vendors picked for similar parts can prevent ordering/supply chain delays.

Controls:

- Programming using ladder logic on Arduino PLC IDE and IQAN.
- Wiring components
- Trial and error learning about addressing over ethernet

Hydraulics:

- Ensure B.O.M matches order forms
- Isolate components during troubleshooting
- Accumulator pre-charge is a balance between distance and speed
- Pump & motor efficiency is better at higher speeds

